

Dorota Walentynowicz
dokumentacja :

1) "At Home with the Kodak" - instalacja

druki promocyjne firmy Kodak z lat 1922-2022

fragmenty broszury "At Home with the Kodak" (1924) czyta Magdalena Gorzelańczyk (nagranie : 13'18")

2) "She-camera" - trzy kameraobiekty na statywach

technika : figuratywna kamera otworkowa na statywie

materiał : kameraobiekty - malowana tektura ; statywy - stal surowa

wymiary :

kameraobiekt 1 : 30 cm x 25 cm x 30 cm; statyw 170 cm x 43 cm x 50 cm

kameraobiekt 2 : 50 cm x 45 cm x 15 cm; statyw 142 cm x 86 cm x 50 cm

kameraobiekt 3 : 52 cm x 52 cm x 15 cm; statyw 120 cm x 50 cm x 43 cm

3) "She-camera" - dziewięć fotografii z serii

technika : naświetlenie metodą otworkową na czarno-białych negatywach 4 x 5 cala,

materiał : wydruki pozytywowe ze skanów na papierze Entrada

wymiary : 32 x 40 cm (3 szt), 60 x 75 cm (2 szt) , 40 x 50 cm (4 szt)

oprawa : szyba muzealna, brzożowe ramy malowane na czarno z dystansami

4) "Search by Image" - trzy drukowane zasłony

technika : screenshot

materiał : poliester

wymiary : 130 x 400 cm

oprawa : system mocowania teł fotograficznych



“At Home with the Kodak” - instalacja, detal



"At Home with the Kodak" - instalacja, detal



"At Home with the Kodak" - instalacja, detal



"At Home with the Kodak" - instalacja



"She-camera" kameraobiekty



"She-camera" kameraobiekty



"She-camera" kameraobiekty 1, 3



"She-camera" kameraobjekt 1

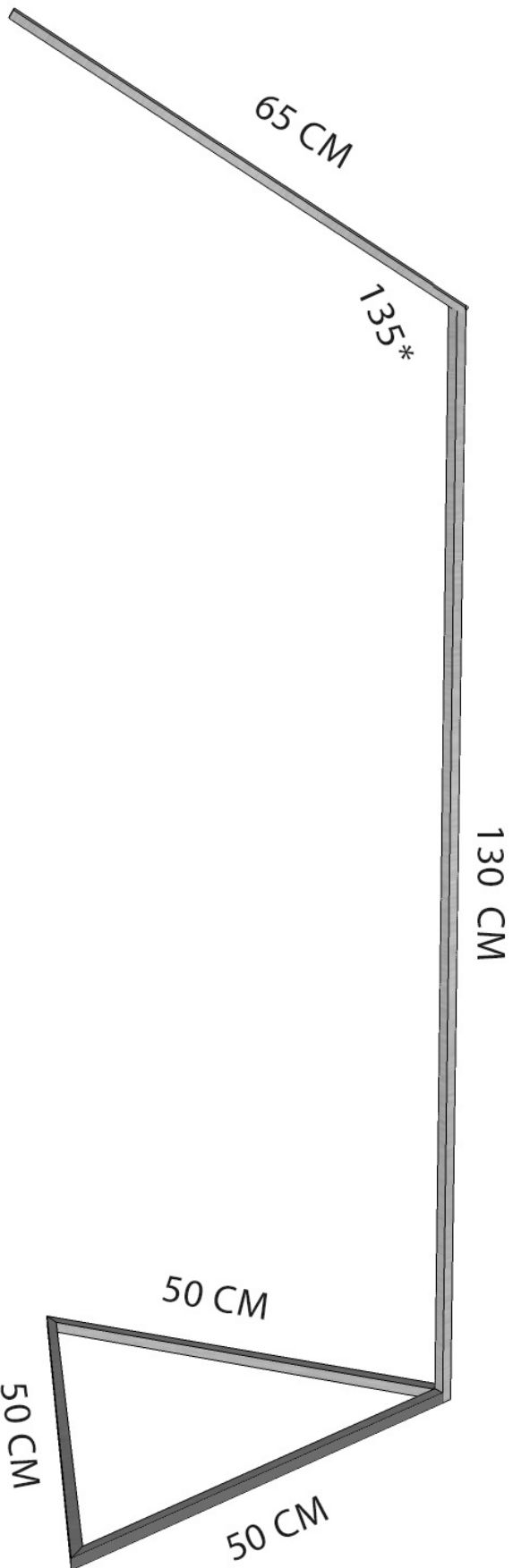



"She-camera" kameraobjekt 2

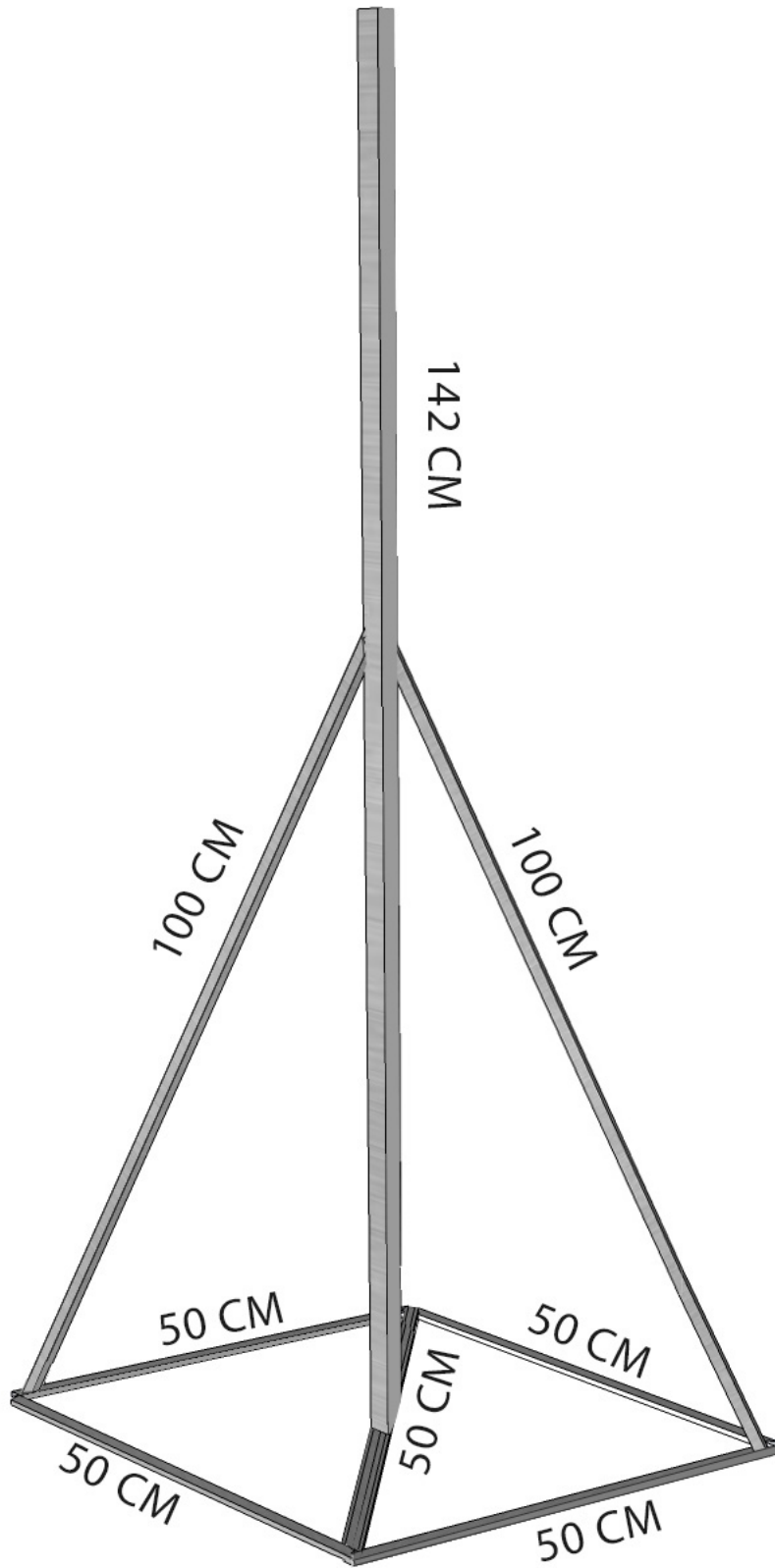



"She-camera" kameraobiekty 3, 1

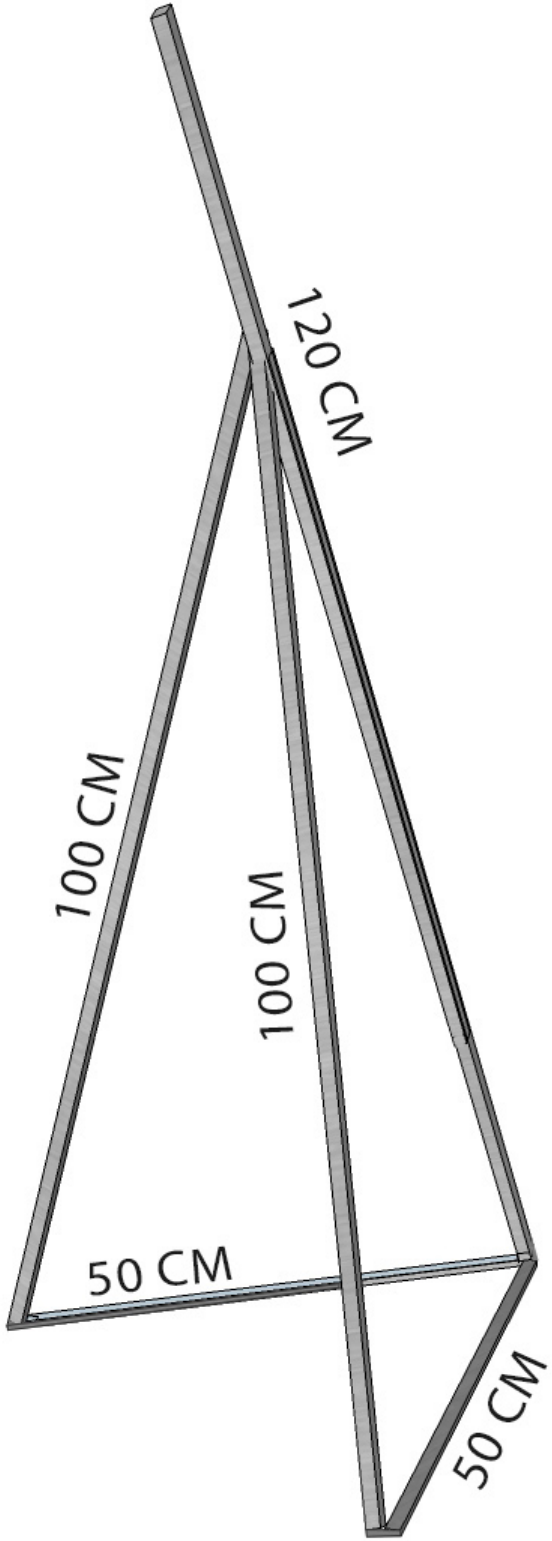



z serii "She-camera" 60x75 cm



z serii "She-camera" 60x75 cm



z serii "She-camera" 50x40 cm

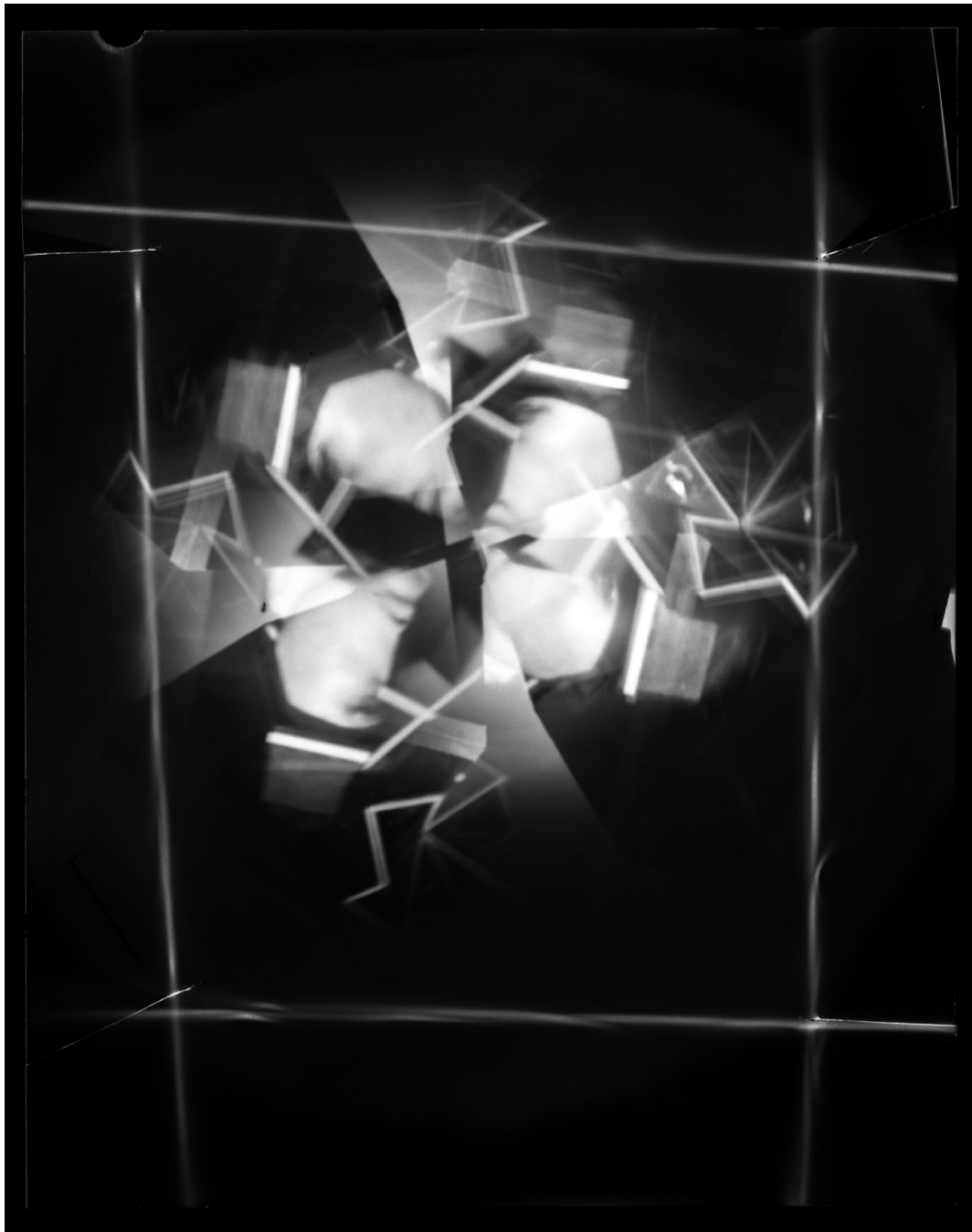

z serii "She-camera" 50x40 cm



z serii "She-camera" 40x32 cm



z serii "She-camera" 40x32 cm

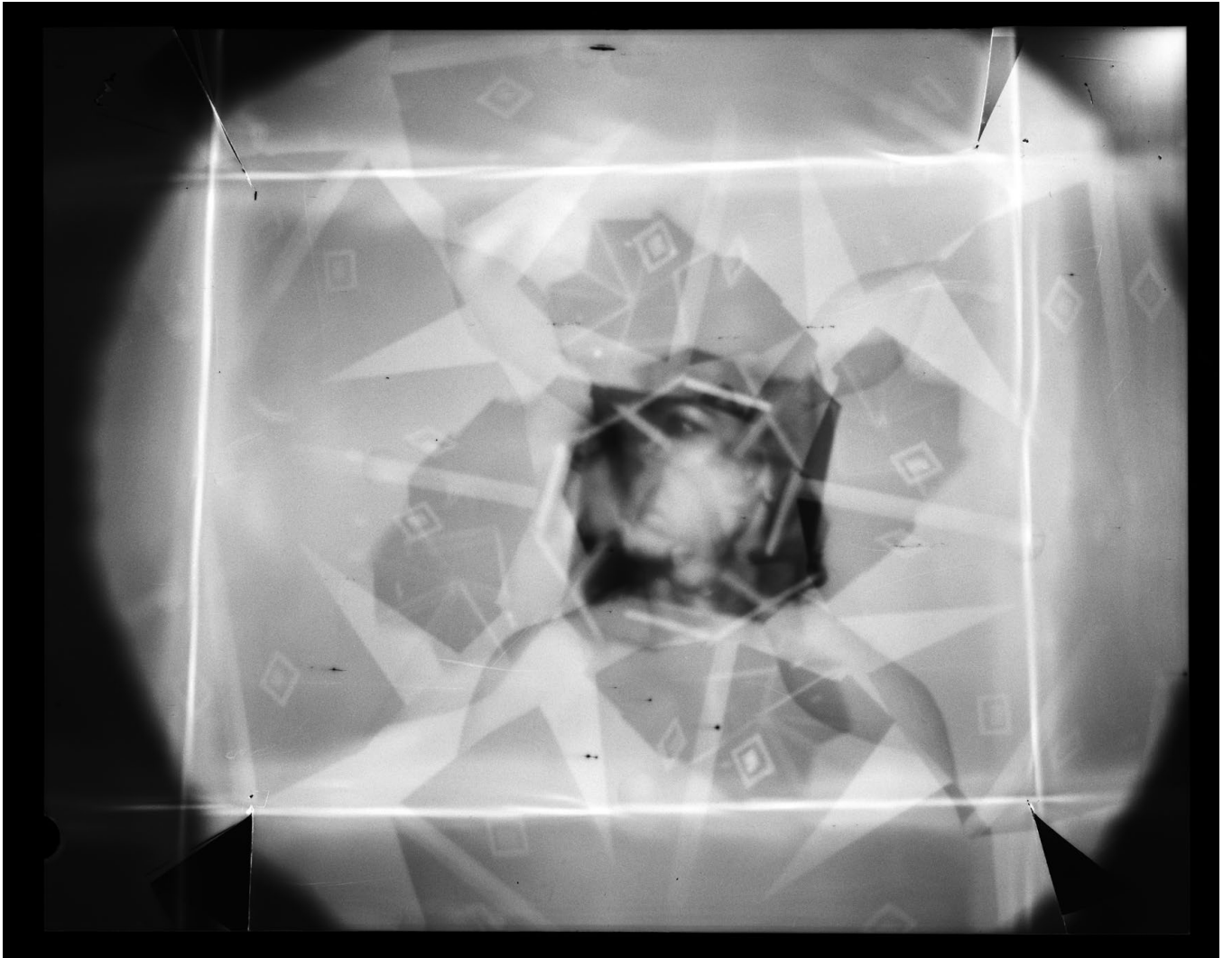

z serii "She-camera" 40x50 cm

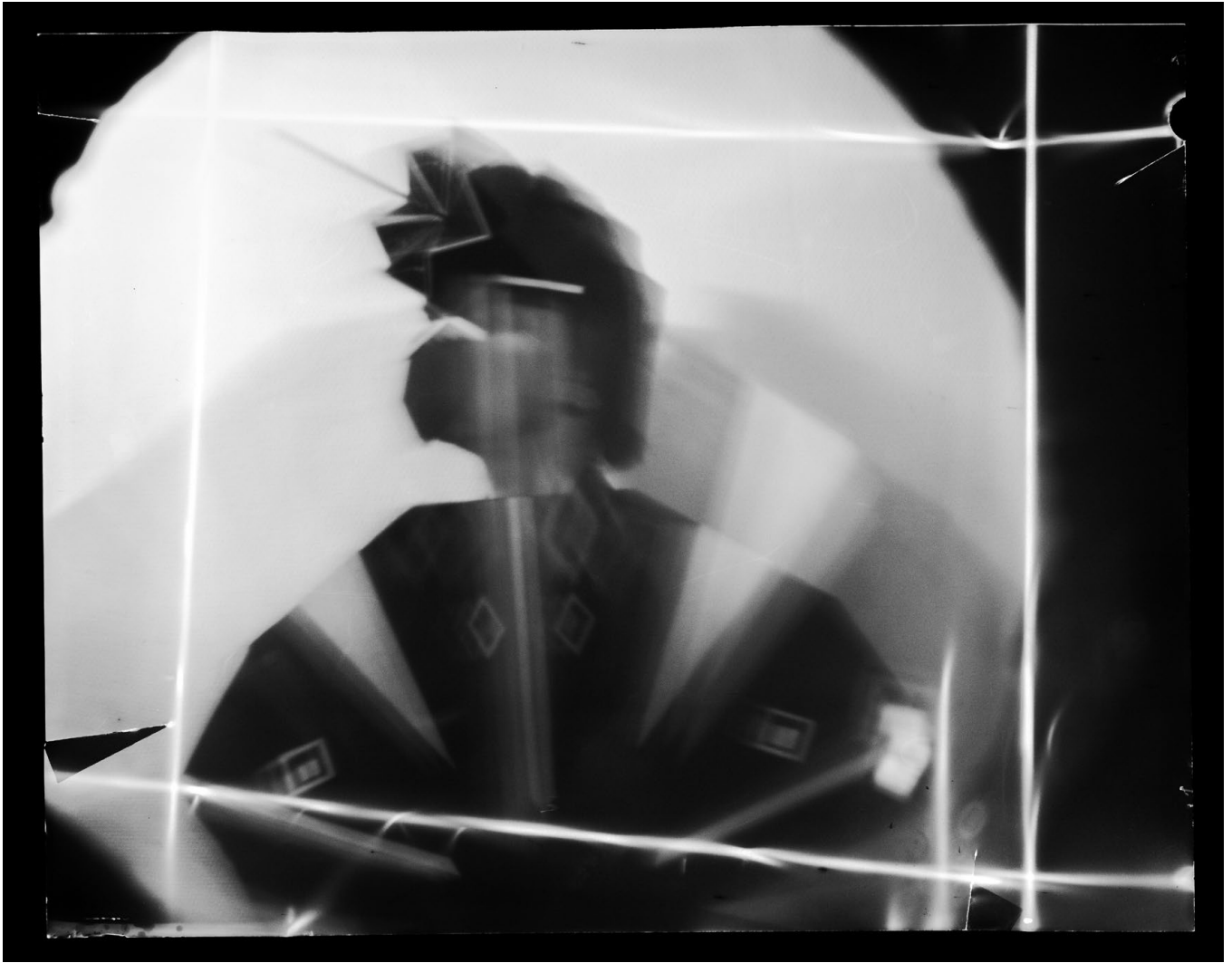

z serii "She-camera" 32x40 cm



z serii "She-camera" 40x50 cm



Search by Image" - drukowane zasłony



Search by Image" - drukowane zasłony





